

Development and Construction of a General-Purpose System to Control Chaos in a Laboratory Plasma

Takao FUKUYAMA and Naoki NISHIDA

Faculty of Education, Nagasaki University, 1-14 Bunkyo-machi, Nagasaki 852-8521, Japan

(Received 5 October 2021 / Accepted 28 November 2021)

A chaos control system based on the time delayed-feedback method was constructed using the LabVIEW system in a laboratory plasma. When the appropriate delay-time and proportionality constant are set as control parameters, the chaotic oscillations are stabilized to be periodic. However, if they are not, the system makes the transition to a more chaotic state. The constructed chaos control system can be widely applied to laboratory plasma by feeding the system back to the dominant location in an electric circuit.

© 2022 The Japan Society of Plasma Science and Nuclear Fusion Research

Keywords: chaos, controlling chaos, delayed-feedback method, synchronization, nonlinear phenomena

DOI: 10.1585/pfr.17.1201002

Controlling chaos is an interesting topic in nonlinear phenomena. An essential idea of controlling chaos is to control a chaotic orbit to an unstable periodic orbit embedded in the chaotic orbit. The Ott, Grebogi, and Yorke method [1] and the delayed-feedback method [2] are well-known methods for controlling chaos. The control of chaos by the delayed-feedback method is versatile for various nonlinear systems. In the field of plasma science, studies on the control of chaotic behavior have been performed, such as the stabilization of the chaos of ionization waves under glow discharge [3] and the stabilization of ion acoustic instability [4] by the delayed-feedback method. The purpose of the present study is to construct a general-purpose chaos control system based on a time delayed-feedback method using the LabVIEW system in a laboratory plasma.

The configuration of the experimental setup is shown in Fig. 1. All the experiments were performed using a glass tube 0.02 m in diameter and 0.75 m in length. After a high vacuum was created in the glass tube, neon gas was introduced at a pressure of approximately 478 Pa. When a strong DC electric field using a regulated power source (HV1.5–0.3, Takasago) was applied to electrodes 60.0 cm apart, a glow discharge occurred between the electrodes, and neon plasma was generated. Ionization waves were excited in the plasma. When the discharge current was varied, the ionization waves exhibited various dynamic behaviors, including chaos [5]. The transformer incorporated in the circuit had a resistance value of 8.0 k Ω . It worked in conjunction with a resistor from 4.7 to 14.1 k Ω to sustain the glow discharge. Time series signals for analysis were obtained as fluctuations in light intensity using a photodiode (S6775, HAMAMATSU) and a LabVIEW system (2020, NI). The signal sampled from the photodiode was

fed back to the original system using a transformer (EF-4N, Shimadzu) incorporated into the circuit after calculation. The time series data is collected at a sampling rate of 0.01 ms. In the feedback process, there is a slight delay-time, mainly due to the transformer.

The proposed method is based on a feedback perturbation built from the difference between the delayed output signal and the output signal itself. The feedback perturbation signal $F(t)$ applied to the chaotic system is adjusted in proportion to the difference between two consecutive values of an arbitrary dynamical variable $x(t)$.

$$F(t) = k[x(t) - x(t - \tau)].$$

In the above equation, τ and k indicate the delay-time and proportionality constant, respectively.

Ionization waves are self-excited instability caused by ionizing collision and have spatial degree of freedom. Typical electron and ion temperatures are approximately 10 eV and 0.025 eV, respectively. The discharge current is important parameter to govern the system.

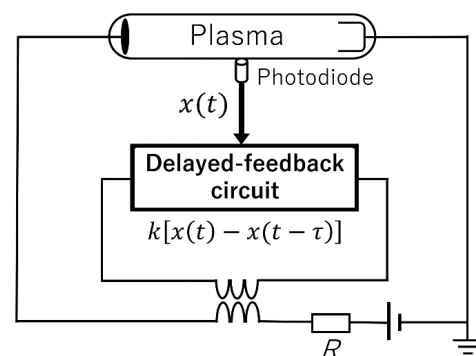

Fig. 1 Configuration of the experimental setup. The delayed-feedback circuit is constructed using a LabVIEW system and general-purpose computer.

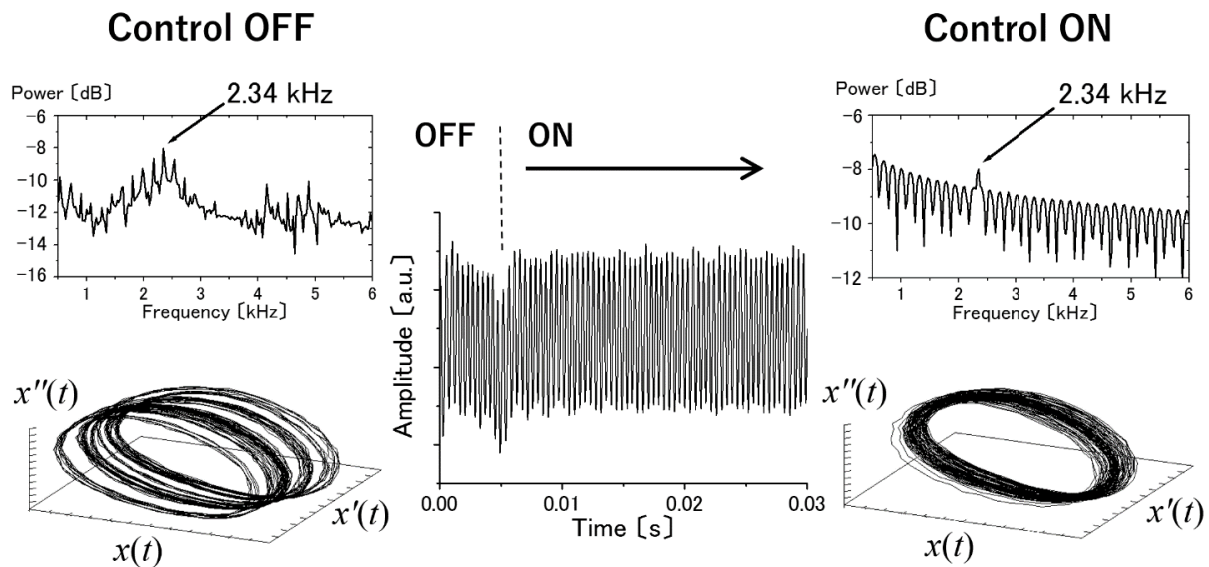

Fig. 2 Time series, power spectrum, and orbit reconstructed in phase space (x' and x'' are constructed by adding a delay-time of 0.1 ms and 0.2 ms, respectively, to the time series signal x), corresponding to the system before and in the process of control. The parameters are as follows: discharge current = 26.8 mA, $\tau = 0.427$ ms (1.0 period of fundamental frequency), and proportional constant $k = 40$ (degree of amplification of the feedback signal; less than 1 percent of the discharge voltage).

In the delayed-feedback system, the chaotic system becomes periodic when an appropriate delay-time and proportionality constant are chosen. Figure 2 shows the time series, power spectrum, and orbit reconstructed in phase space, corresponding to the system before and during the process of control. Here, the parameters are a discharge current of 26.8 mA, delay-time of 0.427 ms (1.0 period of fundamental frequency), and proportional constant $k = 40$ (1.0 period of fundamental frequency; less than 1 percent of the discharge voltage). When the control is turned on, the system changes from a chaotic state to an orderly state.

The delayed-feedback control not only causes the chaos to make the transition to a periodic state but also causes the system to have a more chaotic state if the appropriate delay-time is not chosen. Based on present method to control chaos, chaotic oscillation is stabilized to orderly one, when the delay-time around 1.0 period corresponding to fundamental frequency is selected. Figure 3 shows the time series during the application of the feedback signal to the state shown in Fig. 2. The parameters are a discharge current of 26.8 mA, $\tau = 0.577$ ms (1.35 period), and $k = 40$. The chaotic system is further disturbed and the system makes the transition from the chaotic state to more chaotic one because an appropriate delay-time is not chosen.

The conclusions of this study are summarized below. A system to control the ionization wave chaos based on the time delayed-feedback method was constructed using the LabVIEW system. When the appropriate delay-time and proportionality constant were set, chaotic oscillations were periodically stabilized. Otherwise, the system made the transition from a quasi-periodic state to an intermittent chaotic state. It is believed that the constructed chaos con-

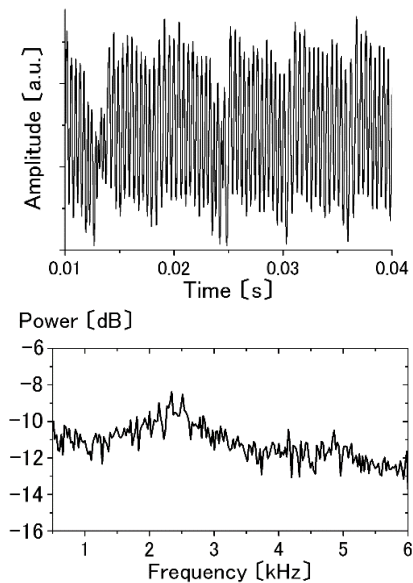

Fig. 3 Time series and power spectrum under applied feedback. The parameters are as follows: discharge current = 26.8 mA, $\tau = 0.577$ ms (1.35 period), and $k = 40$.

rol system can be widely applied to laboratory plasmas. The details of the variation of the system with respect to the delay-time and proportionality constant are the subject of planned future research. This study was supported by JSPS KAKENHI (Grant Number JP20K03895).

- [1] E. Ott *et al.*, Phys. Rev. Lett. **64**, 1196 (1990).
- [2] K. Pyragas, Phys. Lett. A **170**, 421 (1992).
- [3] Th. Pierre *et al.*, Phys. Rev. Lett. **76**, 2290 (1996).
- [4] T. Fukuyama *et al.*, Phys. Plasmas **9**, 4525 (2002).
- [5] T. Fukuyama *et al.*, Plasma Fusion Res. **15**, 2401049 (2020).