

Proposal of New Type Diplexer for ECCD System^{*)}

Mikio SAIGUSA, Shuhei SUGAWARA, Kohei ATSUMI, Yasuhisa ODA¹⁾,
Tomoki YAMAGUCHI and Keishi SAKAMOTO¹⁾

Ibaraki University, Hitachi, Ibaraki 316-8511, Japan

¹⁾*Japan Atomic Energy Agency, Naka, Ibaraki 311-0193, Japan*

(Received 2 December 2011 / Accepted 25 May 2012)

For improving a stabilizing efficiency of neoclassical tearing modes, the new type diplexer as a fast switching device of high power millimeter wave is proposed for an electron cyclotron current driving system. The principle is a ring resonator-type switch consisting of a ring corrugated circular waveguide, a pair of mitre-bends, and a pair of half mirrors. A mock-up diplexer was designed, fabricated, and tested in low power. The switching operation of the mock-up diplexer with slotted metal half mirrors was verified at the frequency bands of 137 GHz and 170 GHz.

© 2012 The Japan Society of Plasma Science and Nuclear Fusion Research

Keywords: NTM, ECCD, fast switching device, diplexer, 170 GHz, half mirror

DOI: 10.1585/pfr.7.2405099

1. Introduction

A neoclassical tearing mode (NTM) which is a resistive MHD instability driven by plasma pressure gradient in tokamak plasma is one of the key issues giving the upper limitation of plasma performance. It can be controlled by the local current drive in a magnetic island with electron cyclotron current drive (ECCD) [1]. Up to now, ECCD with pulse modulated gyrotron operation at duty of 50% have been done to drive current into only O-point. For improving a stabilizing efficiency of NTM, the fast directional switch had been developed [2, 3]. It makes the duty of ECCD system to 100% by switching beam direction for tracking the rotating O-point of a magnetic island of NTM.

The new type diplexer as a fast switching device of high power millimeter wave was proposed and had been simulated with finite difference time domain (FDTD) method [4, 5]. In this paper, the results of low power test of new type diplexer as a high power fast switching device is reported firstly.

2. A Principle of Diplexer

A proposed diplexer consists of a ring corrugated circular waveguide, a pair of mitre-bends, and a pair of half mirrors as shown in Fig. 1. The linearly s-polarized millimeter wave is injected from the port 1. At non-resonant condition, the rf power is mainly transmitted to the port 2, while the rf power is mainly transmitted to the port 4 at the resonant condition. The way to switch is the changing frequency of a gyrotron output between a resonant frequency of the diplexer and a non-resonant one.

Resonant frequencies of a diplexer depend on the res-

onant ring length. On the assumption that the power reflection coefficient of half mirror 1 and 2 is a , the output electric field E_4 from the port 4 normalized by the input electric field E_1 into the port 1 is obtained by the following equation.

$$E_4 = (1 - a) \left[1 + a \exp(i\theta) + (a \exp(i\theta))^2 + \dots \right] \\ = \frac{1 - a}{1 - a \exp(i2\pi L/\lambda)} \left(\theta = \frac{2\pi L}{\lambda} \right). \quad (1)$$

In Eq. (1), L is a resonant ring length, θ is an electrical length of resonant ring, λ is a wavelength of an incident wave.

The rf output power from the port 2 and the port 4 are evaluated to be the following equations, respectively.

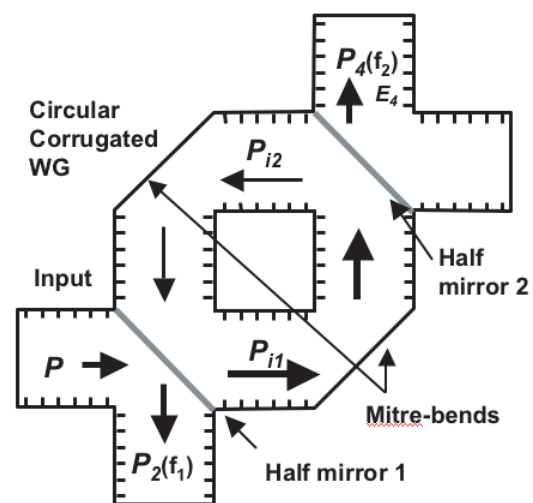

Fig. 1 A schematic view of a ring resonator-type diplexer.

author's e-mail: saigusa@mx.ibaraki.ac.jp

^{*)} This article is based on the presentation at the 21st International Toki Conference (ITC21).

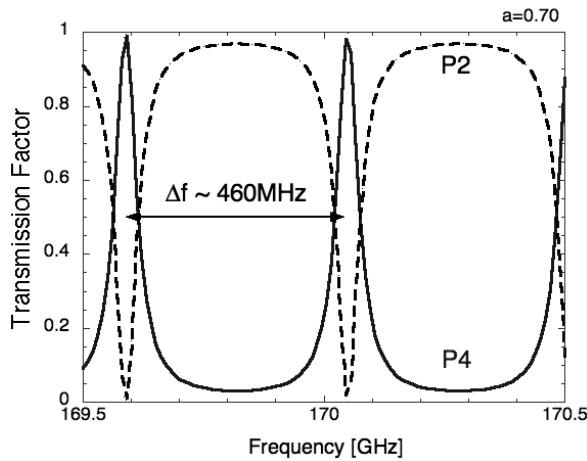

Fig. 2 Typical frequency dependence of transmission factors of a ring resonator-type diplexer.

$$P_2 = 1 - |E_4|^2 = \frac{2a[1 - \cos(2\pi L/\lambda)]}{1 + a^2 - 2a \cos(2\pi L/\lambda)}, \quad (2)$$

$$P_4 = |E_4|^2 = \frac{(1 - a)^2}{1 + a^2 - 2a \cos(2\pi L/\lambda)}. \quad (3)$$

Figure 2 shows the estimated transmission factor against a frequency of an incident wave. The broken line and the solid line show the transmission factor from the port 2 and the port 4, respectively. On the assumption that the power reflection coefficient of half mirrors: a is 0.7, the crosstalk between port 2 and port 4 is 3%, where the crosstalk is defined as the minimum $P_4/(P_2+P_4)$. The larger the power reflection coefficient of half mirrors: a is, the lower a crosstalk is. However, the Q factor of a resonant ring increases with the power reflection coefficient of half mirrors, so that the possibility of break down in a resonant ring increases with the reflection coefficient of half mirrors due to high rf voltage. The resonant frequency interval Δf_{res} of a diplexer can be estimated to be $c/L \sim 460$ MHz, where the resonant ring length: L is assumed to be about 650 mm, c is a velocity of light. The resonant frequency interval should be wider than the chirping frequency (up to 300 MHz) at the gyrotron start-up phase [6].

3. Design of Diplexer

According the simulation results with FDTD methods, the diplexer was designed and fabricated as shown in Fig. 3. Inner diameter of circular corrugated waveguide is 63.5 mm, and the resonant ring length L is about 650 mm. The diplexer was made of aluminum alloy, except for a pair of short plates made of oxygen free copper. The slotted metal half mirrors made of aluminum alloy are installed in the resonant ring, as shown in Fig. 4. The thickness of the half mirrors is 1.7 mm. The period and the width of slots are 2.0 mm and 1.0 mm, respectively. The slot direction is parallel to the incident plane. The electric field of HE_{11} mode is vertical of the incident plane for reducing Ohmic loss of mitre-bends and suppressing counter rotat-

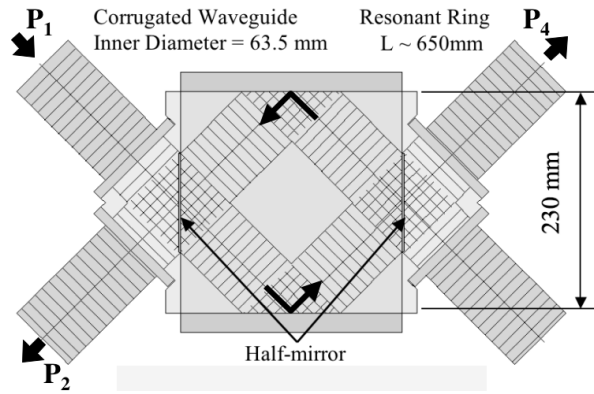

Fig. 3 Schematic view of a designed diplexer.

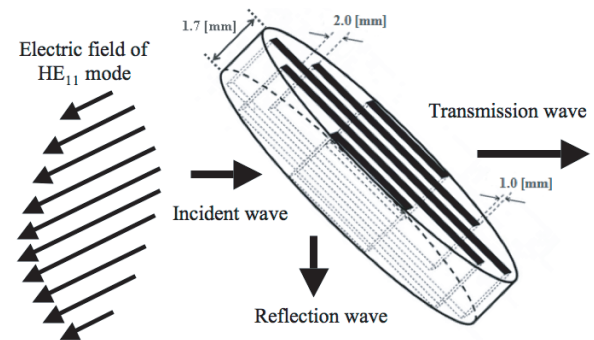

Fig. 4 Schematic view of a slotted metal half mirror.

ing modes in a ring resonator even if the high order diffractions were excited. When a slot period is wider than a wavelength of incident wave, high order diffractions must be generated by the slotted half mirrors. Therefore, the slot period is chosen to be wider than the wavelength of 170 GHz band, and to be narrower than the wavelength of 137 GHz band for studying the effect of high order diffraction on the traveling wave resonance in the ring resonator.

4. Lower Power Experiments

Before the measurements of the features of the diplexer, the power reflection coefficient of slotted metal half mirror was evaluated to be 0.42 at a frequency of 170 GHz. Next, the mock-up diplexer with slotted half mirrors was tested in the low power test-stand as shown in Fig. 5. The input mode is the HE_{11} mode generated by a mode converter. The radiation patterns were measured using a waveguide antenna (WR-6.5: 1.7×0.83 mm) scanned by 2 mm step in the area of 100×100 mm at the distance of 500 mm away from the waveguide edge using the 2-D scan stage.

A frequency dependence of the radiated power from the port 2 and the port 4 on was measured with the horn antenna (16.1×12.2 mm) located on beam center at the distance of 500 mm away from the waveguide edge. The antenna was connected to the heterodyne detecting system consisting of a harmonic mixer, a diplexer, low noise am-

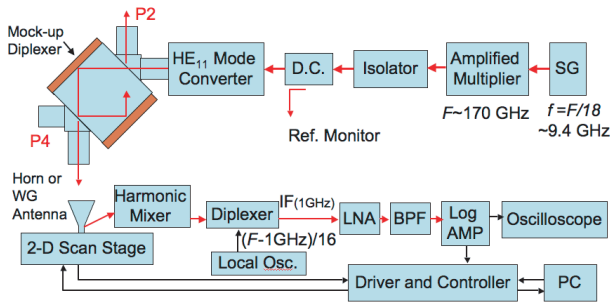

Fig. 5 Schematic view of a low power test stand.

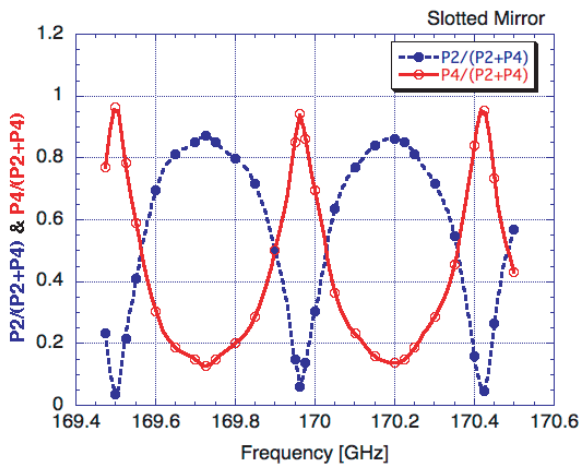

Fig. 6 Frequency dependence of output powers of a diplexer at a frequency band of 170 GHz.

plifiers, a band pass filter, a log amplifier and a local oscillator.

Figure 6 shows the frequency dependence of $P2/(P2+P4)$ and $P4/(P2+P4)$ of the diplexer at the frequency band of 170 GHz.

The crosstalk between port 2 and port 4 is about 13%. The resonant frequency interval Δf_{res} is about 460 MHz. On the assumption that the power reflection coefficient of half mirrors: a is 0.42 and the resonant ring length is 650.9 mm, the transmission factor against a frequency of incident wave is shown in Fig. 7. The experimental results in Fig. 6 almost coincide with the theoretical predictions in Fig. 7.

Figures of 8 (a), 8 (b), 8 (c) and 8 (d) show the radiation patterns from the output ports of the mock-up diplexer at the frequency band of 170 GHz. The horizontal direction is parallel to the incident plane. Both of the patterns of P2 and P4 at power peak indicate HE_{11} modes, as shown in Fig. 8 (a) and Fig. 8 (c). On the other hands, the P4 pattern at minimum power indicates HE_{11} mode as shown in Fig. 8 (b), while the P2 pattern at minimum power indicates the existence of higher modes as shown in Fig. 8 (d). However, the radiation patterns at peak power is much more important rather than those at minimum power as a switch. Therefore, the switching operations were verified from the

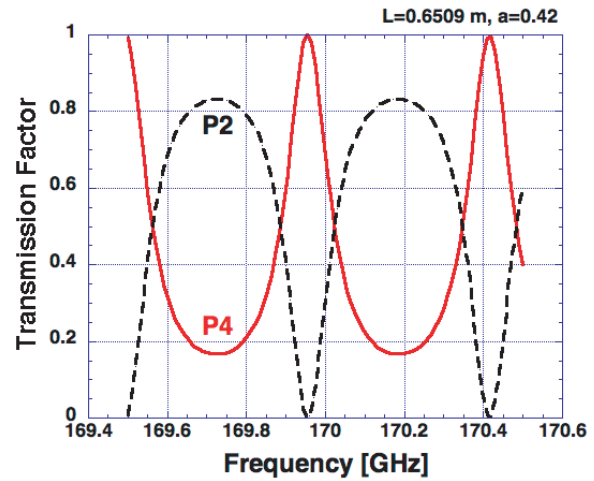

Fig. 7 Theoretical prediction of diplexer feature at a frequency band of 170 GHz.

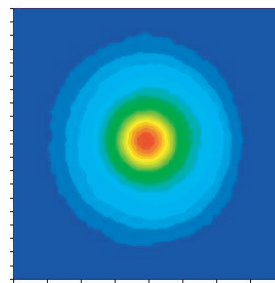

Fig. 8 (a) Radiation pattern of P4 peak at 169.975 GHz.

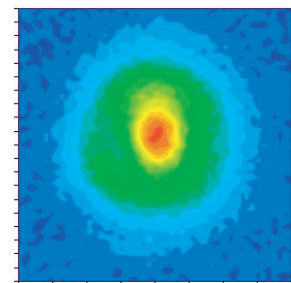

Fig. 8 (b) Radiation pattern of P4 minimum at 170.2 GHz.

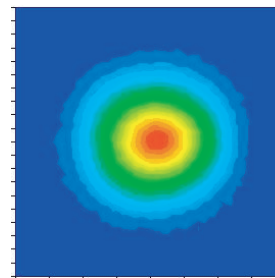

Fig. 8 (c) Radiation pattern of P2 peak at 170.1 GHz.

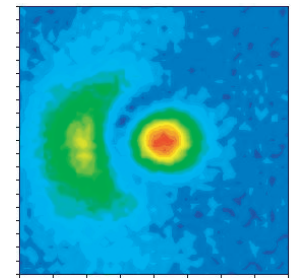

Fig. 8 (d) Radiation pattern of P2 minimum at 169.975 GHz.

data of Fig. 6 and Fig. 8.

For checking a wideband switching operation, the feature of a diplexer has been checked at the frequency band of 137 GHz, where 137 GHz and 170 GHz are the frequencies of a developing multi-frequency gyrotron in JAEA [7]. Figure 9 shows the dependence of $P2/(P2+P4)$ and $P4/(P2+P4)$ on the frequency. In this frequency band, there is no high order diffraction caused by a slotted metal half mirror, because that the slot period (2.0 mm) is shorter than the wavelength of incident wave (~ 2.2 mm). The switching operation can be observed around resonant frequencies, clearly. The measured crosstalk was about 5%. The

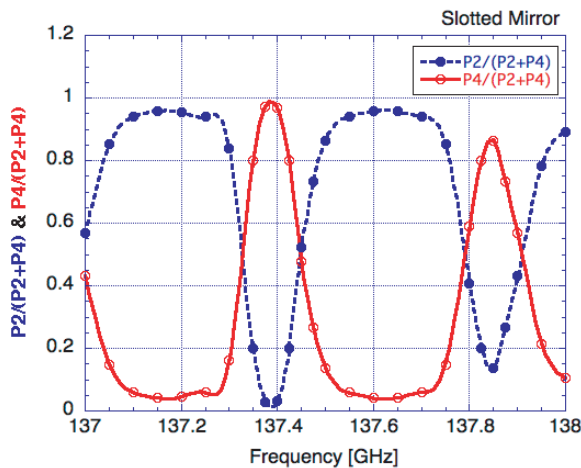

Fig. 9 Frequency dependence of output powers of a diplexer at a frequency band of 137 GHz.

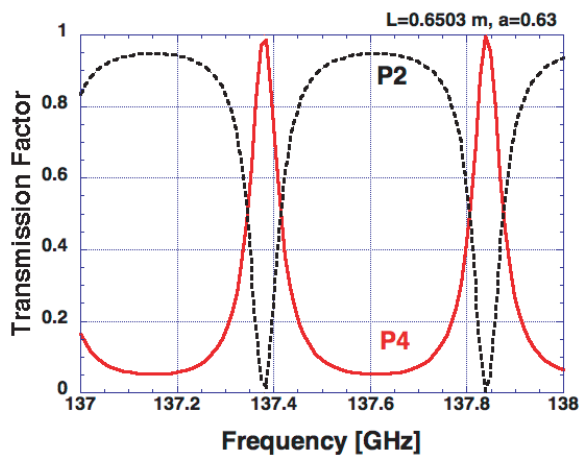

Fig. 10 Theoretical prediction of diplexer feature at a frequency band of 137 GHz.

resonant frequency interval Δf_{res} is about 460 MHz. The gain of the amplified multiplier (OML Inc. S08MS-AG) decreases with increasing the frequency up to 138 GHz.

On the assumption that the power reflection coefficient of half mirrors: a is 0.63 and the resonant ring length is 650.3 mm, the transmission factor against the frequency is shown in Fig. 10. The resonant frequency interval and the crosstalk are coincided with the experimental results, except for the frequency band higher than 137.8 GHz.

Figures of 11(a), 11(b), 11(c) and 11(d) show the radiation patterns from the output ports of the mock-up diplexer at the frequency band of 137 GHz. The horizontal direction is parallel to the incident plane. Any higher modes could not be observed in all radiation patterns due to the no high order diffractions generated by the slotted metal half mirrors.

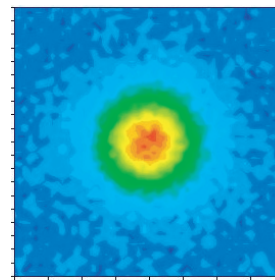

Fig. 11 (a) Radiation pattern of P4 peak at 137.375 GHz.

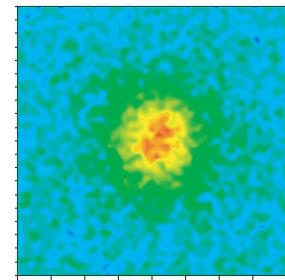

Fig. 11 (b) Radiation pattern of P4 minimum at 137.2 GHz.

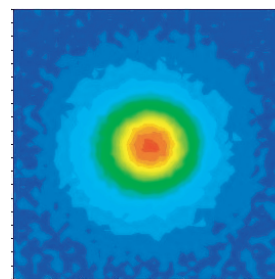

Fig. 11 (c) Radiation pattern of P2 peak at 137.1 GHz.

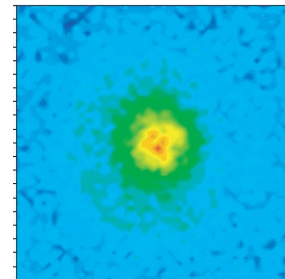

Fig. 11 (d) Radiation pattern of P2 minimum at 137.35 GHz.

5. Conclusions

The new type diplexer as a fast switching device of high power millimeter wave has been being developed for ECCD system. The mock-up diplexer is designed, fabricated, and tested in low power. The switching operation of diplexer with slotted metal half mirrors has been verified at the frequency bands of 137 GHz and 170 GHz.

Acknowledgements

This work has been supported by the Grants-in-Aid for Scientific Research (c) of 22560818. Authors would thank Plasma Heating Group and JT-60 RF Heating Group in JAEA for supporting low power tests.

- [1] H. Zohm, G. Gantenbein, G. Giruzzi, S. Gunter, F. Leuterer, M. Maraschek *et al.*, Nucl. Fusion **39**, 577 (1999).
- [2] M.I. Petelin, "Quasi-optics in high-power millimeter-wave systems," AIP Conf. Proc. **691**, 251 (2003).
- [3] W. Kasperek *et al.*, Fusion Sci. Technol. **52**, 281 (2007).
- [4] M. Saigusa *et al.*, "Fast switching device of high power millimeter wave in ECCD system," Proc. of 13th AMPERE Toulouse (2011) p. 285.
- [5] K. Atsumi *et al.*, "Research and Development of High Power Wideband Diplexer for ECCD System," Plasma Conference 2011, Kanazawa, 23P099-P (2011).
- [6] W. Kasperek *et al.*, Nucl. Fusion **48**, 054010 (2008).
- [7] K. Kajiwara *et al.*, "Development of the high power 170GHz gyrotron for ITER," Proc. of Plasma Conference 2011, Kanazawa, 22D03 (2011).