

# First Results of Magnetized Plasma Flow Injection on the TPE-RX Reversed-Field Pinch

ASAI Tomohiko<sup>2)</sup>, NAGATA Masayoshi<sup>3)</sup>, KOGUCHI Haruhisa<sup>1)</sup>, KIYAMA Satoru<sup>1)</sup>,  
HIRANO Yoichi<sup>1)</sup>, YAGI Yasuyuki<sup>1)</sup> and SASAKITA Hajime<sup>1)</sup>

<sup>1)</sup> National Institute of Advanced Industrial Science and Technology (AIST), Tsukuba, Ibaraki 305-8568, Japan

<sup>2)</sup> College of Science and Technology, Nihon University, Tokyo 101-8308, Japan

<sup>3)</sup> Graduate School of Engineering, University of Hyogo, Himeji, Hyogo 671-2201, Japan

(Received 5 April 2005 / Accepted 22 April 2005)

Magnetic helicity and plasma flow injection experiments using a magnetized coaxial plasma gun on a reversed-field pinch were performed for the first time. In the initial experiments, increases in the electron density and toroidal flux were observed. The dependence of flux change on the polarity of the injected helicity indicates the possibility of the magnetic helicity injection and the poloidal current drive.

**Keywords:** Reversed-Field Pinch (RFP), magnetic helicity, magnetized coaxial plasma gun (MCPG)

A reversed-field pinch (RFP) has the potential to be a simple and economical fusion reactor core. However, it is still necessary to improve the methods of confinement, fueling and sustainment. In the RFP configuration, the poloidal current is sustained through dynamo activity. The dynamo activity is the consequence of tearing instabilities which degrade the energy confinement. Therefore, the poloidal current drive is a longstanding problem in the RFP research to improve energy confinement. The pulse poloidal current drive (PPCD) [1] is an efficient means of solving this problem, but not in the steady-state. We have proposed a method in which a magnetized plasma flow with a large amount of a magnetic helicity contents is injected into the edge region to drive the poloidal current non-inductively. The initial experiments of the magnetized plasma flow injection have been started on the toroidal pinch experiment TPE-RX RFP which is one of the world's largest RFP devices [2].

The magnetized plasma flow is generated by a magnetized-coaxial plasma gun (MCPG) which is mounted radially on the mid-plane of the TPE-RX. Figure 1 shows a schematic view of the MCPG and a poloidal section of the TPE-RX. The injector has a formation capacitor bank of 367mF with a maximum charging voltage of 800V. A set of bias field coils driven by a dc power supply with 16.8V and 300A generates the bias flux up to 9mWb. Two solenoid-valves are mounted on the middle of the outer electrode for deuterium gas-puffing. A

maximum gun current of 40-60kA generates a magnetized plasma flow with 17km/s flow velocity and 3-5 ms duration time. The polarity of the magnetic helicity can be reversed by changing the direction of a bias field. Total helicity  $K_{inj}$  generated by the gun helicity source can be estimated by  $K_{inj} = \int V_g \Psi_b dt$  [3]. Here,  $V_g$  is the gun voltage and  $\Psi_b$  is the bias flux. In the present experiments, the maximum helicity is approximately 2.5mWb<sup>2</sup>. Typical gun discharge waveforms are shown in Fig.2.

The experiments were performed with a flattop plasma current  $I_\phi$  of 230 kA and line-averaged electron density  $\langle n_e \rangle$  of  $5 \times 10^{18} \text{ m}^{-3}$ . The operating condition was chosen to avoid a saw-tooth crash, which would hinder observation of the response of the RFP to plasma flow injection. In this experiment,

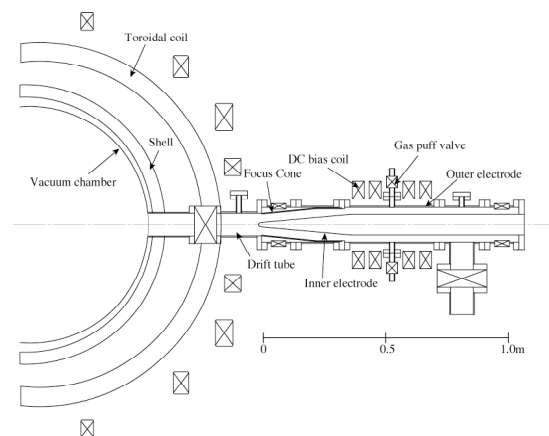

Fig.1 Schematic view of MCPG and a poloidal section of TPE-RX RFP

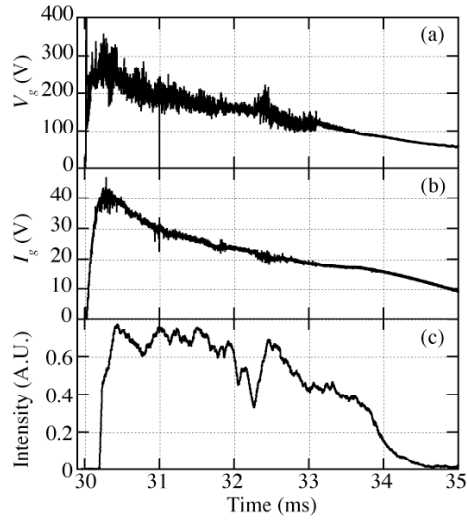

Fig.2 Typical waveforms of gun discharge; (a) gun voltage, (b) current, (c) D $\alpha$  spectrum.

the trigger time of MCPG was fixed at  $t = 30$  ms from the start of  $I_\phi$ . Typical time evolutions of  $I_t$  and  $\langle n_e \rangle$  are shown in Fig.3. The curve in Fig.3(b) shows the twofold increase in  $\langle n_e \rangle$ ; from  $4 \times 10^{18}$  to  $8 \times 10^{18} \text{ m}^{-3}$  with  $\sim 2.5$  ms rise time. The particle content increased by  $\Delta N_{RFP} (= \Delta n_g \times V_p) \sim 2.8 \times 10^{19}$  and the particle inventory of the plasma flow was  $N_{inj} \sim 3.8 \times 10^{19}$ . Therefore, the fueling efficiency  $\varepsilon = \Delta N_{RFP} / N_{inj}$  was roughly 74% [4]. This increase rate was approximately twice as fast as that in the case of single-operation gas-puffing on MCPG (dashed line). Note that the impurity line intensities of Mo II and Fe I did not show any apparent increase of influx rate during the injection.

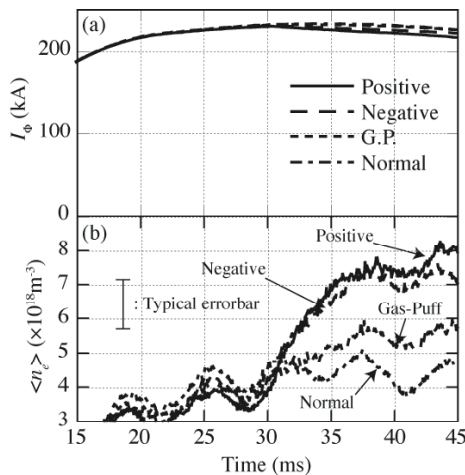

Fig.3 Time evolution of (a) plasma current  $I_\phi$  and (b) line averaged electron density  $\langle n_e \rangle$ .

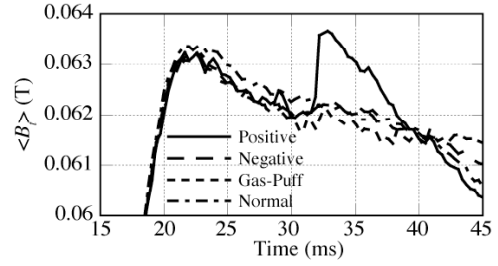

Fig.4 Time evolution of volume averaged toroidal magnetic field.

We observed an increase of the toroidal flux, which exhibited a clear dependence on the polarity of the injected magnetic helicity. Figure 4 shows time evolutions of the volume averaged toroidal magnetic field. In the case of positive (the same sign as the target RFP) helicity injection, the field increased by approximately 2.4%. On the other hand, almost no change was observed either in the negative-polarity or gas-puff cases. At the toroidal position where the injector is mounted, the cross-sectional average toroidal field increases by approximately 10%, which propagates toroidally in the direction of  $I_\phi$ . These results indicate the possibility of an edge dynamo electric field induced by positive helicity injection and a self-generation of the toroidal flux.

In summary, the magnetic helicity injection experiments via magnetized plasma flow have been started successfully on TPE-RX RFP. The fueling effect of plasma flow injection has been clearly shown. Also, an increase in the toroidal flux due to the magnetized plasma flow injection and its dependence on the helicity polarity have been observed. Further investigation on the mechanism of the poloidal current drive and flow effect is underway, and shall be reported elsewhere.

This work is supported by Grants-in-Aid for Scientific Research and the Budget for Nuclear Research from the Ministry of Education, Culture, Sports, Science and Technology of Japan.

- [1] S.Sarff *et al.*, Phys. Rev. Lett. **78**, 62 (1997).
- [2] Y.Yagi *et al.*, Fusion Eng. Design **45**, 409 (1999).
- [3] D.C.Barnes *et al.*, Phys. Fluids **29**, 2616 (1986).
- [4] N. Fukumoto, *et al.* Nuclear Fusion **44**, 982 (2004) .