

Design of Power Supply for Magnet Systems of Thailand Tokamak-1^{*)}

Nopporn POOLYARAT, Suebsak SUKSAENGPANOMRUNG¹⁾ and Wutthichok SANGWANG

Center for Advanced Nuclear Technology, Thailand Institute of Nuclear Technology, Thailand

¹⁾*Electrical Engineering Department, King Mongkut's University of Technology Thonburi, Thailand*

(Received 28 November 2019 / Accepted 1 September 2020)

Thailand Tokamak-1 is a small size tokamak, formerly known as HT-6M and belong to Institute of Plasma Physics, Chinese Academy of Science (ASIPP, China). The HT-6M was donated to Thailand Institute of Nuclear Technology (TINT, Thailand) and will undergo a reconstruction in order to re-commission again. For the reconstruction of power supply for magnet systems, three circuits have been designed based on capacitor discharge for the toroidal field magnet coil, the heating field magnet coils, and the vertical field magnet coils. With a simulation of new circuit design, the TT-1 will have toroidal magnet field about 1.5 T for a flattop duration of 100 ms with Ohmic heating and vertical magnetic field of the same duration.

© 2020 The Japan Society of Plasma Science and Nuclear Fusion Research

Keywords: power supply, Thailand Tokamak-1, tokamak, circuit design, magnet coil

DOI: 10.1585/pfr.15.2405079

1. Introduction

Thailand Tokamak-1, formerly known as HT-6M [1], is a small size tokamak donated to Thailand Institute of Nuclear Technology (TINT, Thailand) by Institute of Plasma Physics, Chinese Academy of Science (ASIPP, China) under a Memorandum of Understanding for scientific cooperation to help Thailand on fusion technology. The HT-6M produced and provided many scientific understanding during the commission periods, such as micro-turbulence study [2], edge Ohmic heating study [3], edge plasma turbulence [4], modulated toroidal current [5], pellet injection [6], etc. The HT-6M has been commissioned until 2002. After that time, almost all of the supporting system, i.e. power supply system for the magnet, plasma control system, vacuum system, data acquisition system were removed. Therefore, it is necessary to design the new supporting system, especially, the power supply for magnet coils system in order for re-commissioning again, when it will be renamed to Thailand Tokamak-1 [TT-1]. Due to limitation of existing magnet coils, the design policy for the power supply of TT-1 has to adopt physical constrains of the existing magnet coils, i.e. number of coils, maximum tolerable current of each coil, into account for the test, then make the improvement later on.

2. Physical Parameter of TT-1

The size of vacuum chamber of the TT-1 are listed in Table 1.

The TT-1 has 34 ports (14 horizontal ports, 20 vertical

Table 1 TT-1 Chamber dimension.

Parameter	Value (unit)
Major radius	0.65 m
Minor radius	0.20 m

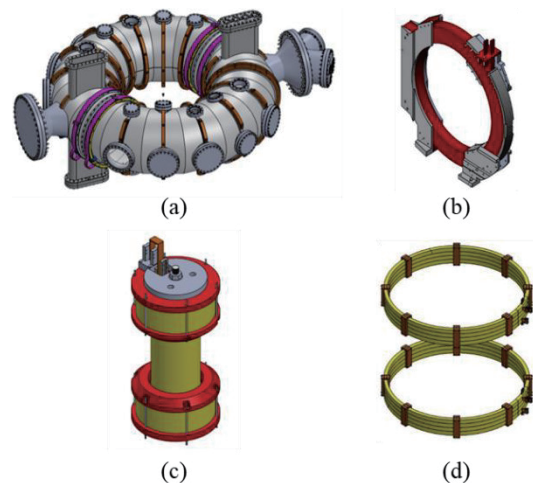

Fig. 1 Components of TT-1 (a) Vacuum Chamber (b) One of 16-TF coils (c) HF coils (d) VF coils.

ports) and shown in Fig. 1 (a). The TT-1 has three sets of magnet coils namely 1) the Toroidal Field TF coils, 2) the Heating Field (HF) coils, and 3) the Vertical Field (VF) coils.

2.1 The TF coils

The TF coils consists of 16 equivalent coils connected in series connected. Each coil consists of 40 winding of

author's e-mail: noppornp@tint.or.th

^{*)} This article is based on the presentation at the 28th International Toki Conference on Plasma and Fusion Research (ITC28).

copper wire. The total inductance and total resistance are 65 mH and 254 mΩ, respectively. The maximum current to the TF coil is 7.6 kA.

2.2 The HF coils

The HF coils consists of two sections, the central coil and two ring heating coils position above and below vacuum chamber. The central coil consists of 6 layers of 30 winding of copper wire. The two sections, consists of 4 layers of 30 winding of copper wire, are connected in series with a total inductance and total resistance equal to 4.37 mH and 25.5 mΩ respectively. The maximum current to the HF coils is 17 kA.

2.3 The VF coils

The VF coils consists of two rings, top and bottom ring, each ring consists of 32 winding of copper wire. The total inductance and total resistance of the VF coils are 8.42 mH and 30 mΩ respectively. The VF coils can withstand the current up to 4.8 kA.

3. Circuit Design and Current Profiles

The circuit design for the toroidal field coil is based on simple capacitor discharge. The vertical field circuit is coupled to the heating field circuit to take advantage of discharged current from the heating field circuit. In the current design, the effect of eddy current in the chamber is not included. Once determined its influent, the circuit will be corrected. Also, for the initial phase of TT-1, the horizontal field coil and power supply circuit are not included. From the aforementioned conditions, the circuit is designed as shown in Fig. 2. The inductance and resistance for coils

and cables, along with the capacitance used in Fig. 2. are listed in Table 2, Table 3, and Table 4. The circuit, which

Table 2 Inductance of coils and cables in TF, HF, and VF circuit.

Parameter	Value
TF Coil Inductance (LT)	65 mH
TF Cable Inductance (LTT)	2 μH
HF Coil Inductance (LH)	4.37 mH
HF Cable Inductance (LHT)	2 μH
VF Coil Inductance (LV)	8.42 mH
VF Cable Inductance (LVT)	2 μH
L1	5 mH
L2	100 μH
L3	200 μH
L4	5.8 mH

Table 3 Resistance of coils and cables in TF, HF, and VF circuit.

Parameter	Value
TF Coil Resistance (RT)	254 mΩ
TF Cable Resistance (RTT)	10 mΩ
HF Coil Resistance (RH)	25.5 mΩ
HF Cable Resistance (RHT)	2 mΩ
VF Coil Resistance (RV)	30 mΩ
VF Cable Resistance (RVT)	2 mΩ
R1	200 mΩ
R2	300 mΩ
R3	300 mΩ

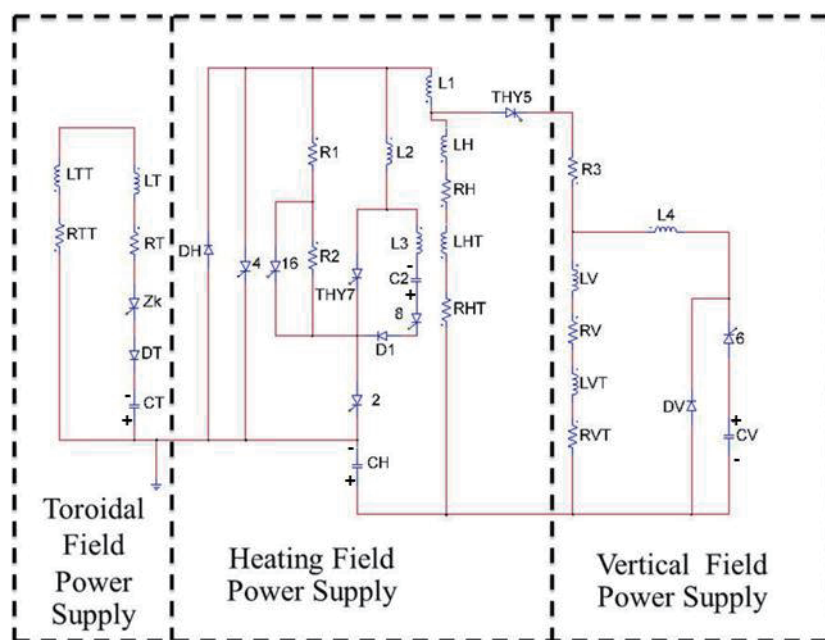

Fig. 2 Power Supply Circuit for the toroidal field (TF), heating field (HF), and vertical field (VF) coils.

Table 4 Capacitance in TF, HF, and VF circuits.

Parameter	Capacitance	Maximum Charging Voltage
TF capacitance (CT)	254 mF	5 kV
HF capacitance (CH)	10 mF	5 kV
VF capacitance (CV)	25.5 mF	10 kV
C2 capacitance (C2)	1.56 mF	10 kV

can be separated into three power supplies for each magnet coil systems The current profiles for these power supplies are simulated and are shown in the Fig. 3 along with the thyristor control signals.

For the toroidal field power supply, as shown in Fig. 2 (left). The main constituents of toroidal field circuit consists of a pulse power supply for discharging energy from the capacitor (CT) to the coils, the vacuum switch (Zk) for proceeding as a switch to turn on/off the discharging, diode (DT) for preventing the reverse voltage and current of the capacitor, the cable in wiring (RT, LT) and the toroidal magnetic field coils (RTT, LTT) contains the resistance and inductance. The equivalent circuit of the toroidal field power supply system consists of the fundamental series RLC circuit where current can be calculated by the mathematical model.

$$I(t) = (2\alpha U(t)/\beta R) \cdot \exp(-\alpha t) \cdot \sin(\beta t),$$

where $\alpha = R/2L$ and $\beta = \sqrt{(1/LC) - (R/2L)^2}$.

The time of the current peak can be determined by taking a derivative to a current which is a time-dependent function and set it to equal zero.

$$dI(t)/dt = 0 \Rightarrow t_p = \tan^{-1}(\beta/\alpha),$$

and the needed charging voltage to impose a capacitor is calculated by

$$U_{\text{charging}} = (R\beta I_p \exp(\alpha t_p))/(2\alpha \sin \beta t_p).$$

Due to current withstanding limitation of TF coils at 7.6 kA, therefore, TF power supply is designed to deliver peak current of 7.6 kA. For the operating period, it is chosen between times at 95% peak current in TF coil (7.22 kA), this yields a time period of 100 ms. This period is referred as flattop period.

For the heating field and vertical field power supply, as shown in Fig. 2 middle and right, the energy is generated by a pulse power supply to the heating field coils by capacitor through the first path to the switch THY7 until the peak of current reach to the maximum 17 kA, then the path of current flow will be altered to the resistor R1 and R2 by drawing a switch THY7 off and turn on a switch #8 instead. The maximum mutual inductance between the HF coil and the VF is calculated to be 16.85 mH.

The removing process of switch THY7, the forced commutation technique is chosen, we use the thyristor so-called Self-commutated by an LC circuit which an inductor

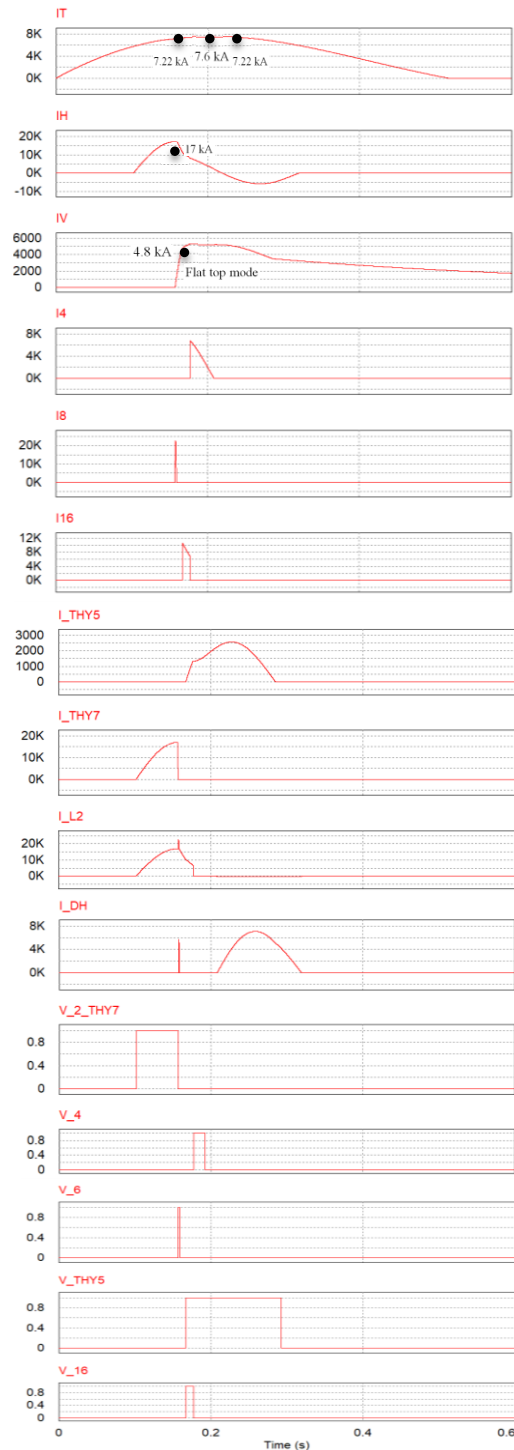

Fig. 3 Simulated Current Profiles of TF, HF, VF coils, sequence of thyristor control and current through thyristor.

L3 and a capacitor C2 connected in series, but parallel to the thyristor THY7 in turning off the thyristor as shown in a Fig. 2. The peak of a pulse current can be considered according to the effect of the resonating by equation

$$I_{\text{resonant peak}} = V_{C2} \cdot \sqrt{C2/L3}.$$

For this design, the capacitance C2 is 1.56 mF, an inductance L3 is 200 μ H and the charging voltage is 10 kV

so that the peak of pulse current quite high to 25 kA, but this peak value will be dropped by the connection of an inductor L2 since it blocks suddenly change of current.

The resistances are added extensively in the new path, therefore it causes the output current rate of change at the heating field coils, and fabricate a reverse loop voltage to make plasma current erupt. In addition to the reason for stabilizing the erupted plasma current and preventing the plasma current run to the wall, the vertical field coils are needed to be held in the circuit by turn on switch #6. The peak of the current is around 4.8 kA after that the switch 5# is turned on for fastening two constituents of the heating field and vertical field power supply together for maintaining the longer time of the flat top mode. Similarly, switch #16 also turned on at the same time with switch 5#, so the resistance R2 is taken away from the system, the time constant extends since the resistance is reduced. Finally, the resistance R1 is shorted by the turning on of switch #4, the time constant extends again as we can see in the discharging current graph of the heating field power supply, the slope of the graph separates into two parts. The simulations of currents in TF, HF, and VF circuit are shown in Fig. 3.

Sequence of thyristor control:

1. At $t = 0$ ms: Vacuums switch (Zk) is triggered and current discharged to the Toroidal field coil
2. At $t = 102$ ms: Thyristor #2 and THY7 are triggered simultaneously and discharged to the Heating field coil
3. At $t = 157$ ms: Thyristor #6 is triggered and discharged to the Vertical field coil then a THY7 is turned off and a

thyristor #8 triggered simultaneously

4. At $t = 167$ ms: Thyristor #16 is triggered to short circuit over a resistor R2 and thyristor #5 triggered to transfer the power from the Heating field coil to the Vertical field coil
5. At $t = 177$ ms: Thyristor #4 is triggered to short circuit over a resistor R1

4. Discussion and Summary

Three power supply circuits have been designed and simulated for the current profiles sent to the magnet coils of TT-1 tokamak. In this design, the TT-1 would have toroidal magnetic field approximately 1.5 T at the center of the toroidal chamber with approximately 100 ms duration. The only plasma heating source is by Ohmic heating from the HF power supply is also designed to synchronize duration with the flattop TF current.

Acknowledgement

This work is done via collaboration with ASIPP, China. The authors would like to acknowledge the grant from Electricity Generating Authority of Thailand (EGAT) for TT-1 reconstruction.

- [1] HT-6M Team, Fusion Technol. **9**, (3), 476 (1986).
- [2] Zeng Lei *et al.*, Chinese Phys. Lett. **10**, 482 (1993).
- [3] Gao Xiang *et al.*, Chinese Phys. Lett. **11**, 161 (1994).
- [4] Wang Wen-Hao *et al.*, Chinese Phys. Lett. **18**, 396 (2001).
- [5] Mao Jian-shan *et al.*, Plasma Sci. Technol. **5**, 1641 (2003).
- [6] Yu Yang *et al.*, Nucl. Fusion **39**, 1871 (1999).